



Selection: Open-Type Reciprocating Compressors

Input Values

Compressor model	4H.2Y-K	Useful superheat	100%
Refrigerant	R404A	Motor speed	1450 /min
Reference temperature	Dew point temp.	Drive	Coupling (1:1)
Liq. subc. (in condenser)	0 K	Capacity control	100%
Suction gas temperature	20,00 °C		

Result

Q [W]	Cooling capacity	COP [-]	COP/EER
Q* [W]	Cooling capacity *	COP* [-]	COP/EER *
P [kW]	Power input	m [kg/h]	Mass flow
Qc [W]	Condenser capacity	n [/min]	Compr. speed

tc	to	0°C	-5°C	-10°C	-15°C	-20°C	-25°C	-30°C	-35°C
30°C	Q [W]	69409	57868	47870	39232	31799	25437	20024	15454
	Q* [W]	69409	57868	47870	39232	31799	25437	20024	15454
	P [kW]	14,95	14,41	13,65	12,71	11,63	10,46	9,25	8,03
	Qc [W]	84356	72279	61519	51938	43427	35896	29270	23485
	COP [-]	4,64	4,02	3,51	3,09	2,73	2,43	2,17	1,92
	COP* [-]	4,64	4,02	3,51	3,09	2,73	2,43	2,17	1,92
	m [kg/h]	1764	1454	1191	968	779	619	485	373
	n [/min]	1450	1450	1450	1450	1450	1450	1450	1450
40°C	Q [W]	60016	49979	41247	33675	27135	21517	16719	12651
	Q* [W]	60016	49979	41247	33675	27135	21517	16719	12651
	P [kW]	17,15	16,28	15,19	13,94	12,58	11,16	9,74	8,36
	Qc [W]	77171	66255	56433	47611	39713	32679	26460	21015
	COP [-]	3,50	3,07	2,72	2,42	2,16	1,93	1,72	1,51
	COP* [-]	3,50	3,07	2,72	2,42	2,16	1,93	1,72	1,51
	m [kg/h]	1722	1415	1155	934	747	588	454	342
	n [/min]	1450	1450	1450	1450	1450	1450	1450	1450
50°C	Q [W]	50320	41860	34458	28005	22404	17568	13416	9875
	Q* [W]	50320	41860	34458	28005	22404	17568	13416	9875
	P [kW]	19,50	18,30	16,91	15,38	13,77	12,14	10,54	9,03
	Qc [W]	69817	60158	51366	43386	36179	29711	23960	18905
	COP [-]	2,58	2,29	2,04	1,82	1,63	1,45	1,27	1,09
	COP* [-]	2,58	2,29	2,04	1,82	1,63	1,45	1,27	1,09
	m [kg/h]	1676	1373	1116	897	711	553	420	307
	n [/min]	1450	1450	1450	1450	1450	1450	1450	1450

-- No calculation possible (see message in single point selection)
 *According to EN12900 (20°C suction gas temp., 0K liquid subcooling)

Application Limits Standard 4H.2

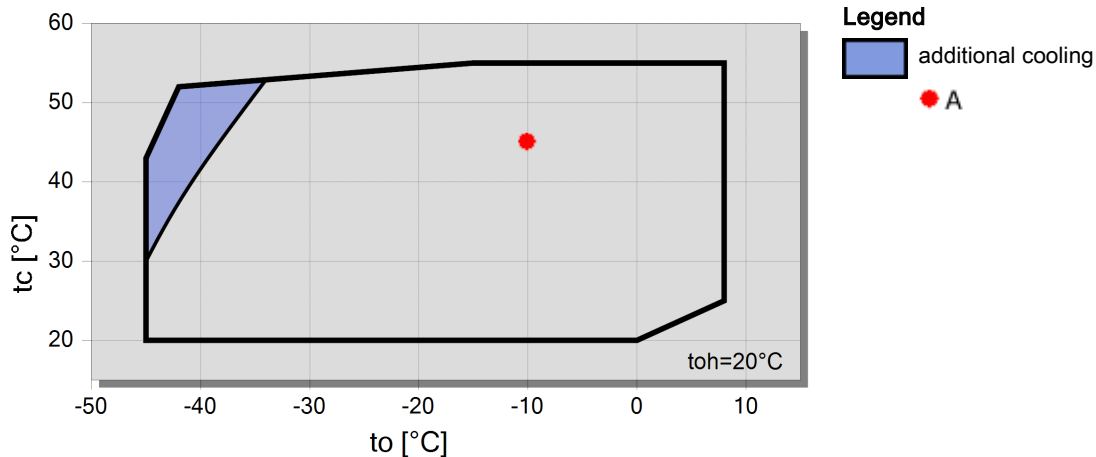



Technical Data: 4H.2Y-K

Dimensions and Connections

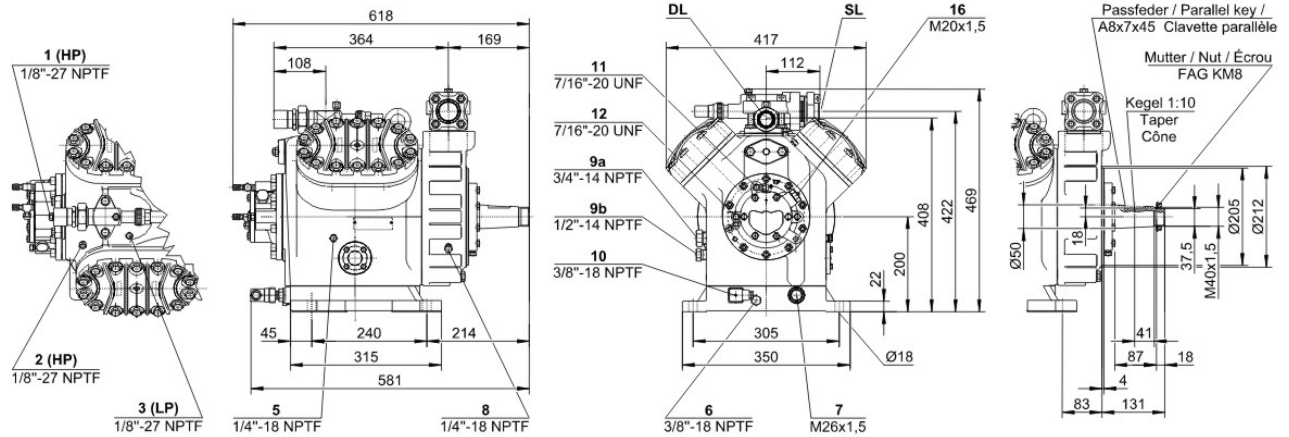

Technical Data

Technical Data

Displacement (1450 RPM 50Hz)	73,6 m3/h
Displacement (1750 RPM 60Hz)	88,8 m3/h
No. of cylinder x bore x stroke	4 x 70 mm x 55 mm
Allowed speed range	750 .. 1750 1/min
Weight	129 kg
Max. pressure (LP/HP)	19 / 25 bar
Connection suction line	42 mm - 1 5/8"
Connection discharge line	28 mm - 1 1/8"
Oil type R134a/R407C/R404A/R507A/R407A/R407F	tc<55°C: BSE32 / tc>55°C: BSE55 (Option)
Oil type R22 (R12/R502)	B5.2 (Standard)

Extent of delivery (Standard)

Oil charge	4,7 dm3
Protective charge	Standard
Suction shut-off valve	Standard
Discharge shut-off valve	Standard
Pressure relief valve	Standard

Available Options

Coupling (...-K) w. A/C + medium	KK620 [<22kW] / KK630 [<45kW] (Option)
Coupling (...-K) w. low temp.	KK625 [<22kW] / KK630 [<45kW] (Option)
Coupling housing	Option
Motor pulley (...-S)	190, 210, 230 mm (Option)
V-belts	5 x SPA (Option)
Discharge gas temperature sensor	Option (incl. INT69VS)
Start unloading	Option
Connection cooling water	R 3/4" (Option)
Capacity control	100-50% (Option)
Additional fan	Option
Water-cooled cylinder heads	Option
Oil service valve	Option
Crankcase heater	140 W (Option)
Oil pressure monitoring	MP54 (Option)
Kit for marine application	Option



Open-Type Reciprocating Compressors

Motor Selection

The required driving motor is selected for starting conditions at direct start as well as at star-delta- or PW-start with start unloading (bypass + check valve). The starting conditions refer to the following defined operation points resp. to the maximum application limit of the compressor. Should the evaporation- or the condensing temperature of the plant be higher at the start, an individual motor selection is necessary.

Evaporation temperature for motor selection				
	HH	H	M	L
R134a	+20 °C	+12,5 °C	-5 °C	-20 °C
R404A / R507A		+7,5 °C	-5 °C	-20 °C
R407F / R407A				
R22		+12,5 °C	-5 °C	-20 °C
NH ₃	+15 °C	+10 °C	-5 °C	

The stated motor data refer to IEC motors at which the pull-up torque does not fall below 90% of the max. torque. In addition the following starting torques (referring to direct starting torque) must be reached:

- * 2-cylinder compressors 220 %
- * 4-cylinder compressors 180 %
- * 6-cylinder compressors 160 %

Should the motor not fulfil these criteria, an individual selection is also necessary.

Condenser capacity

The condenser capacity can be calculated with or without heat rejection. This option can be set in the menu Program Options. The heat rejection is constantly 5% of the power consumption. The condensing capacity is to be found in the line cond.cap. (with HR) resp. cond.cap.

Legend of connection positions according to "Dimensions":

- 1 High pressure connection (HP)
- 2 Connection for discharge gas temperature sensor (HP) (for 4VE(S)-6Y .. 4NE(S)-20(Y) connection for CIC sensor as alternative)
- 3 Low pressure connection (LP)
- 4 CIC system: injection nozzle (LP)
- 4b Connection for CIC sensor
- 4c Connection for CIC sensor (MP / operation with liquid subcooler)
- 5 Oil fill plug
- 6 Oil drain
- 7 Oil filter (magnetic screw)
- 8 Oil return (oil separator)
- 8* Oil return with NH₃ and insoluble oil
- 9 Connection for oil and gas equalization (parallel operation)
- 9a Connection for gas equalization (parallel operation)
- 9b Connection for oil equalization (parallel operation)
- 10 Oil heater connection
- 11 Oil pressure connection +
- 12 Oil pressure connection -
- 13 Cooling water connection
- 14 Intermediate pressure connection (MP)
- 15 Liquid injection (operation without liquid subcooler and with thermostatic expansion valve)
- 16 Connection for oil monitoring (opto-electrical oil monitoring "OLC-K1" or differential oil pressure switch "Delta-PII")
- 17 Refrigerant inlet at liquid subcooler
- 18 Refrigerant outlet at liquid subcooler
- 19 Clamp space
- 20 Terminal plate
- 21 Maintenance connection for oil valve
- 22 Pressure relief valve to the atmosphere (discharge side)
- 23 Pressure relief valve to the atmosphere (suction side)
- SL Suction gas line



DL Discharge gas line

Dimensions can show tolerances according to EN ISO 13920-B.